

Documentation electrical frame model 501-15

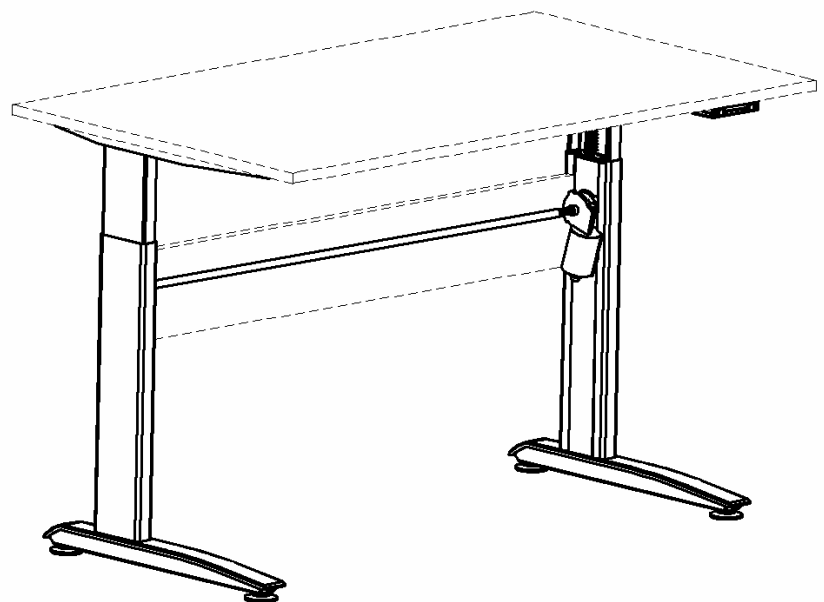
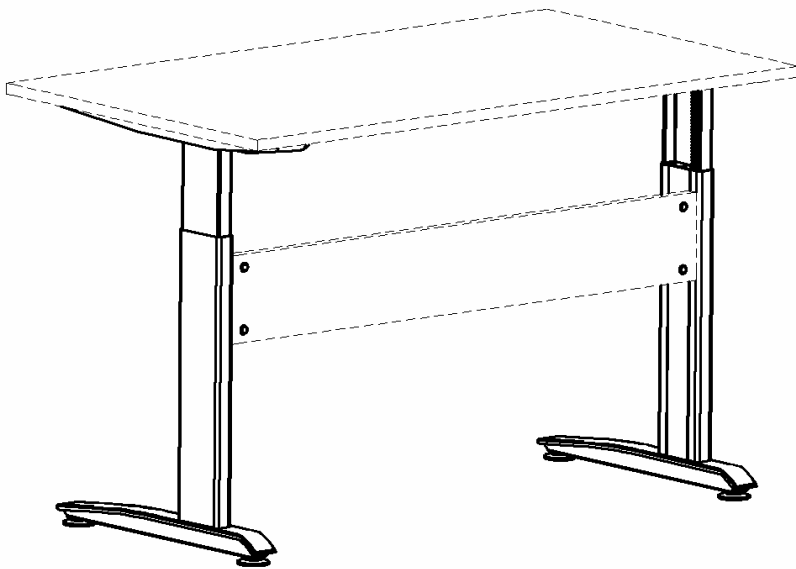
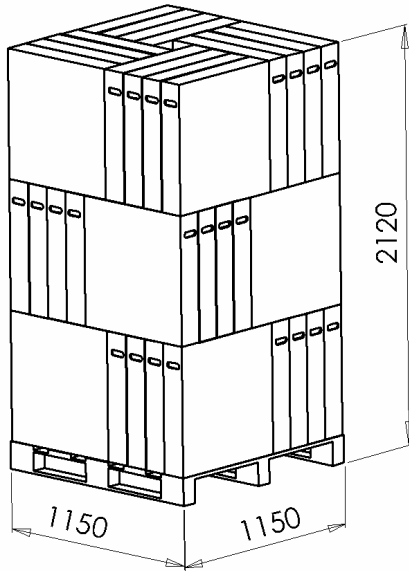

Table of contents

Technical specifications	page 3
Main measures	page 4
Specification, wooden parts	page 5
Specification, carrier tube	page 7
Assembly and use	page 8
Specification, components	page 9

Technical specifications

Packing



Pallet containing 48 pcs. set of frames.
Weight total 1000 kg

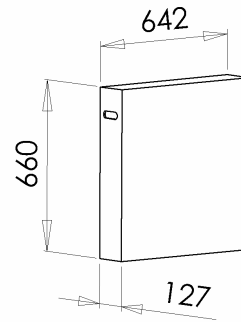

Weight 20 kg

Content of packing

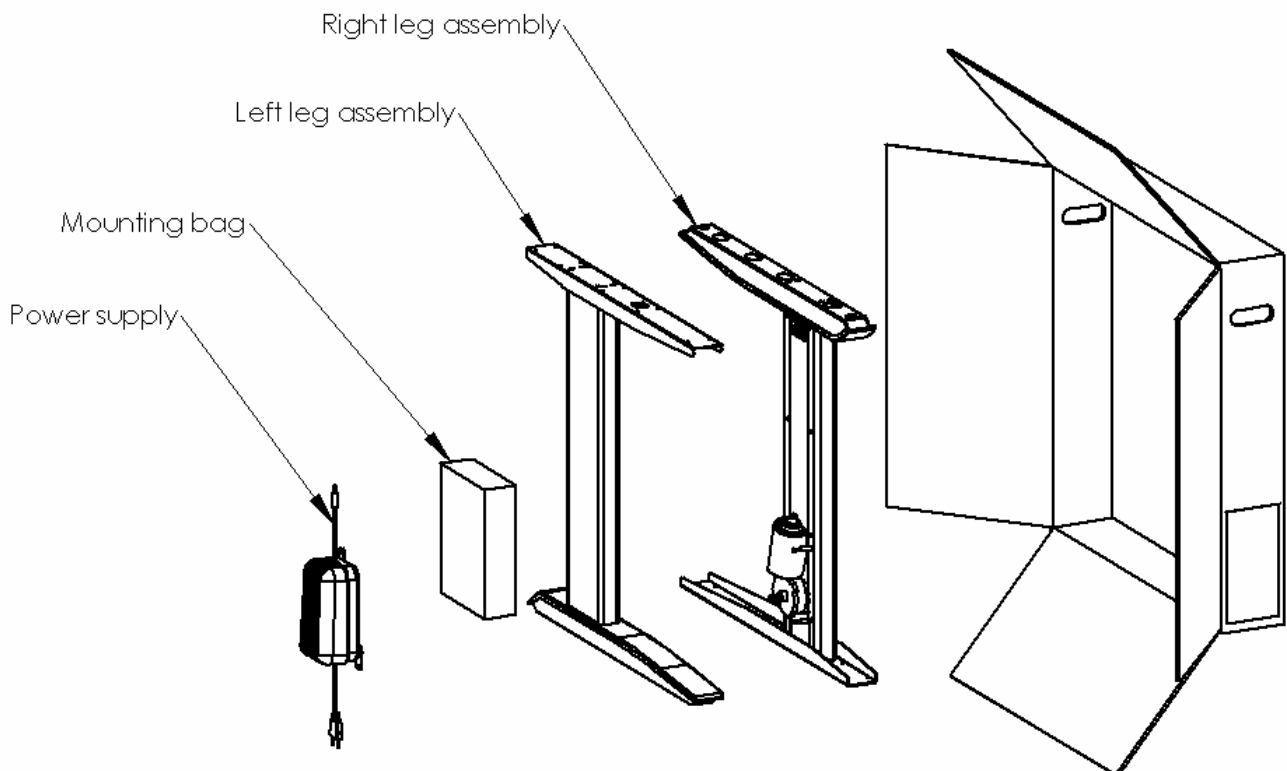

Main measures

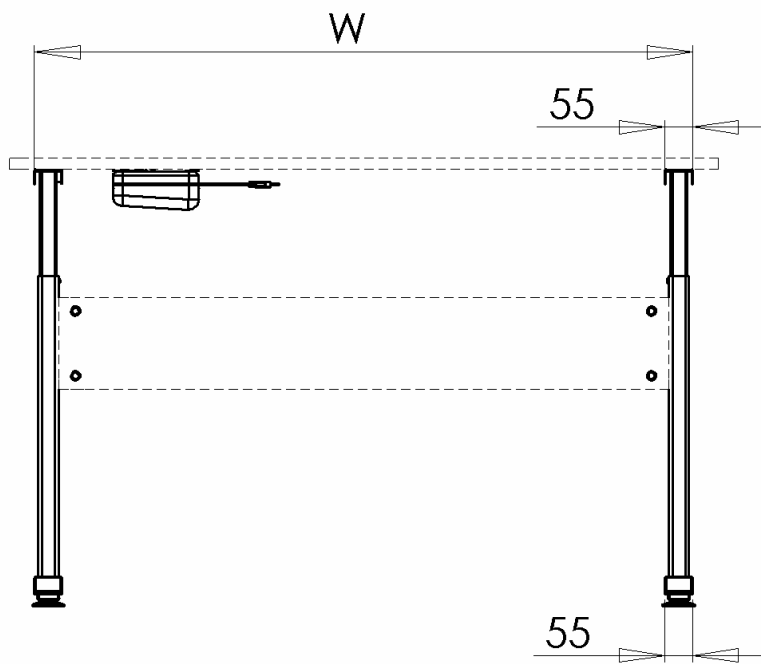
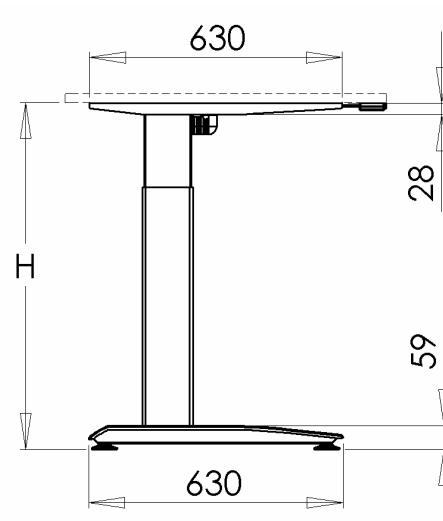

H (height), frame only	66 - 118cm
W (width)	Specified by customer
Lifting capacity, frame	70 kg
Speed	25 mm/sec

Specification, tabletop

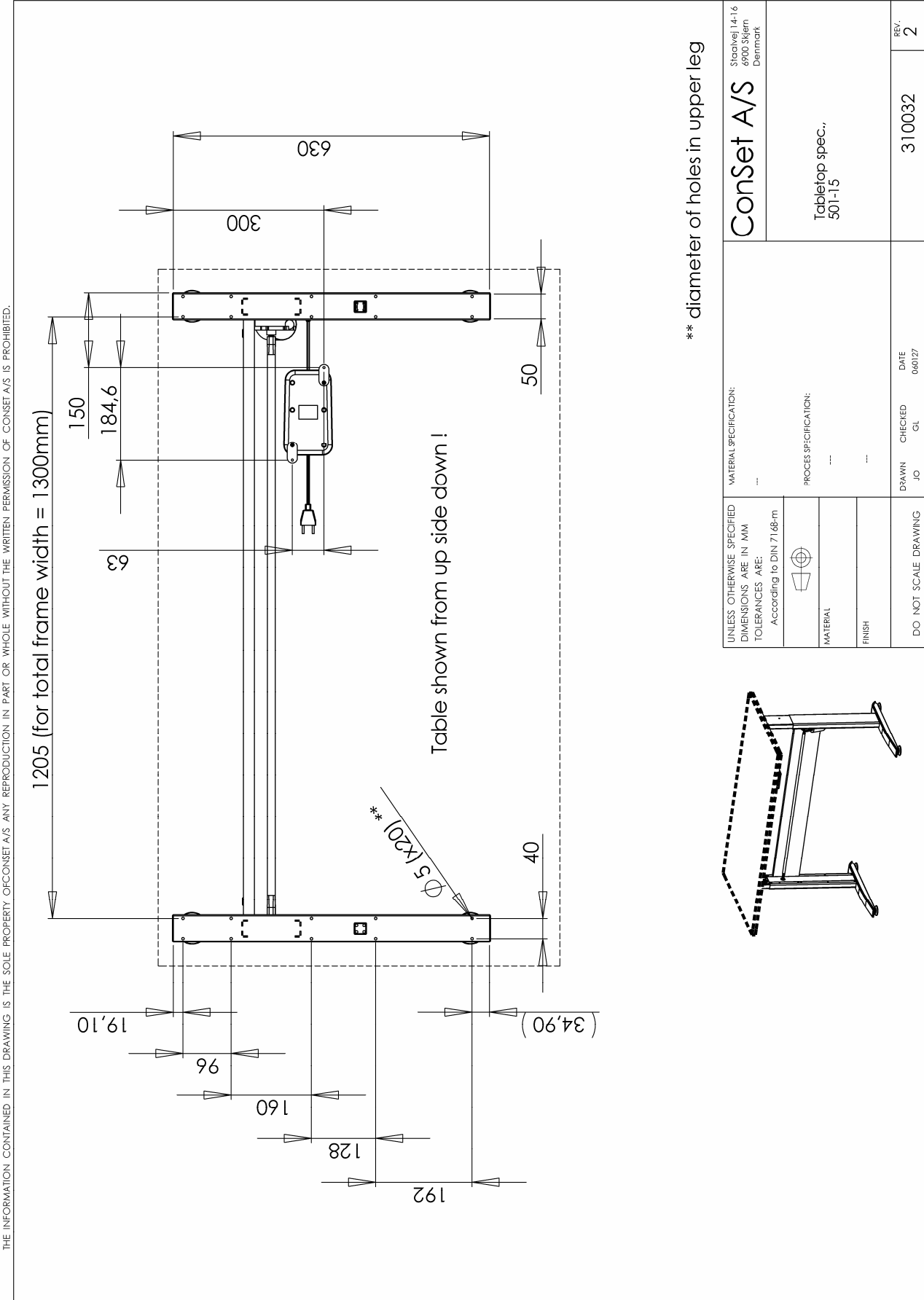

Specification, lower travers

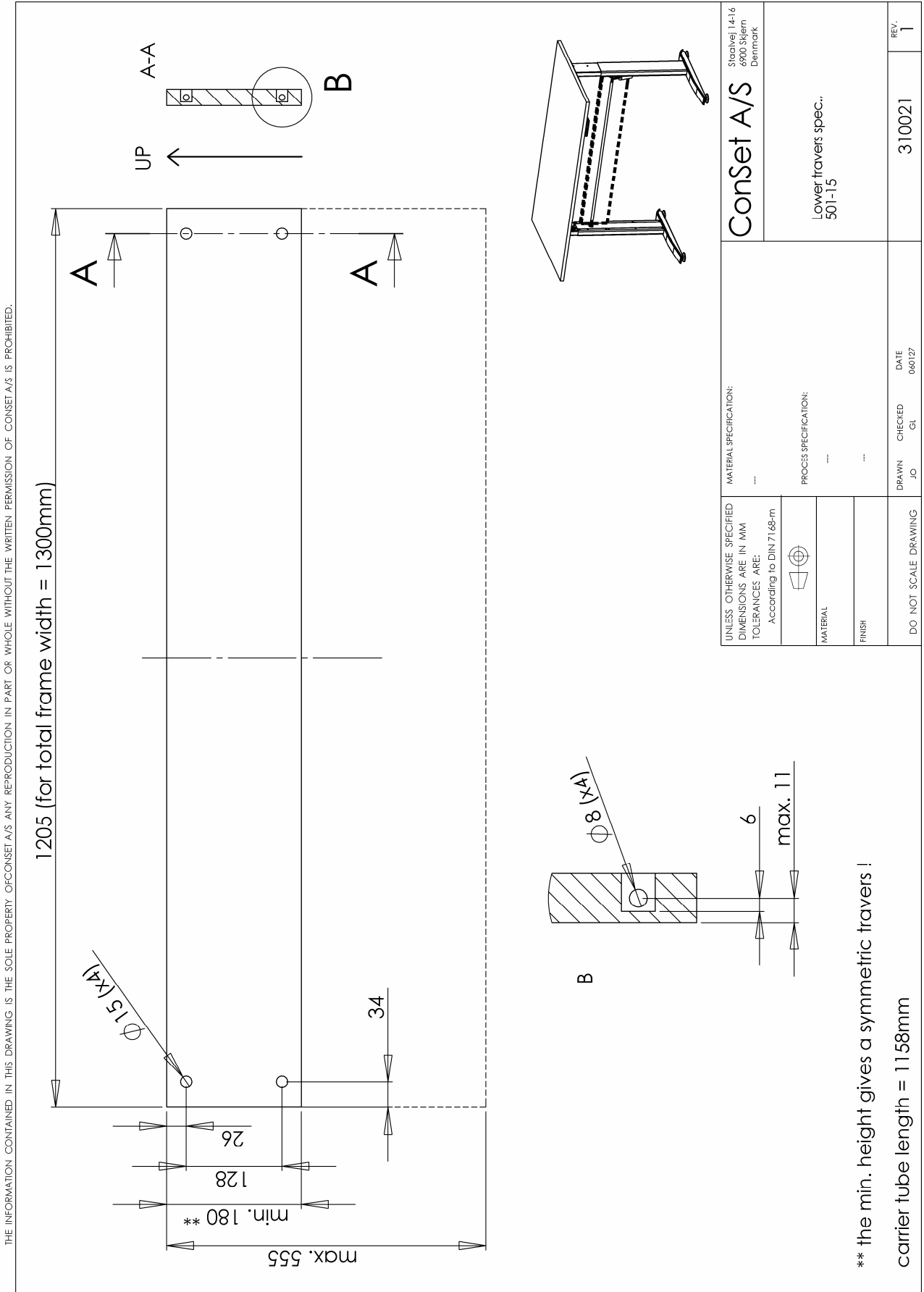

Specification, carrier tube

THE INFORMATION CONTAINED IN THIS DRAWING IS THE SOLE PROPERTY OF CONSET A/S ANY REPRODUCTION IN PART OR WHOLE WITHOUT THE WRITTEN PERMISSION OF CONSET A/S IS PROHIBITED.

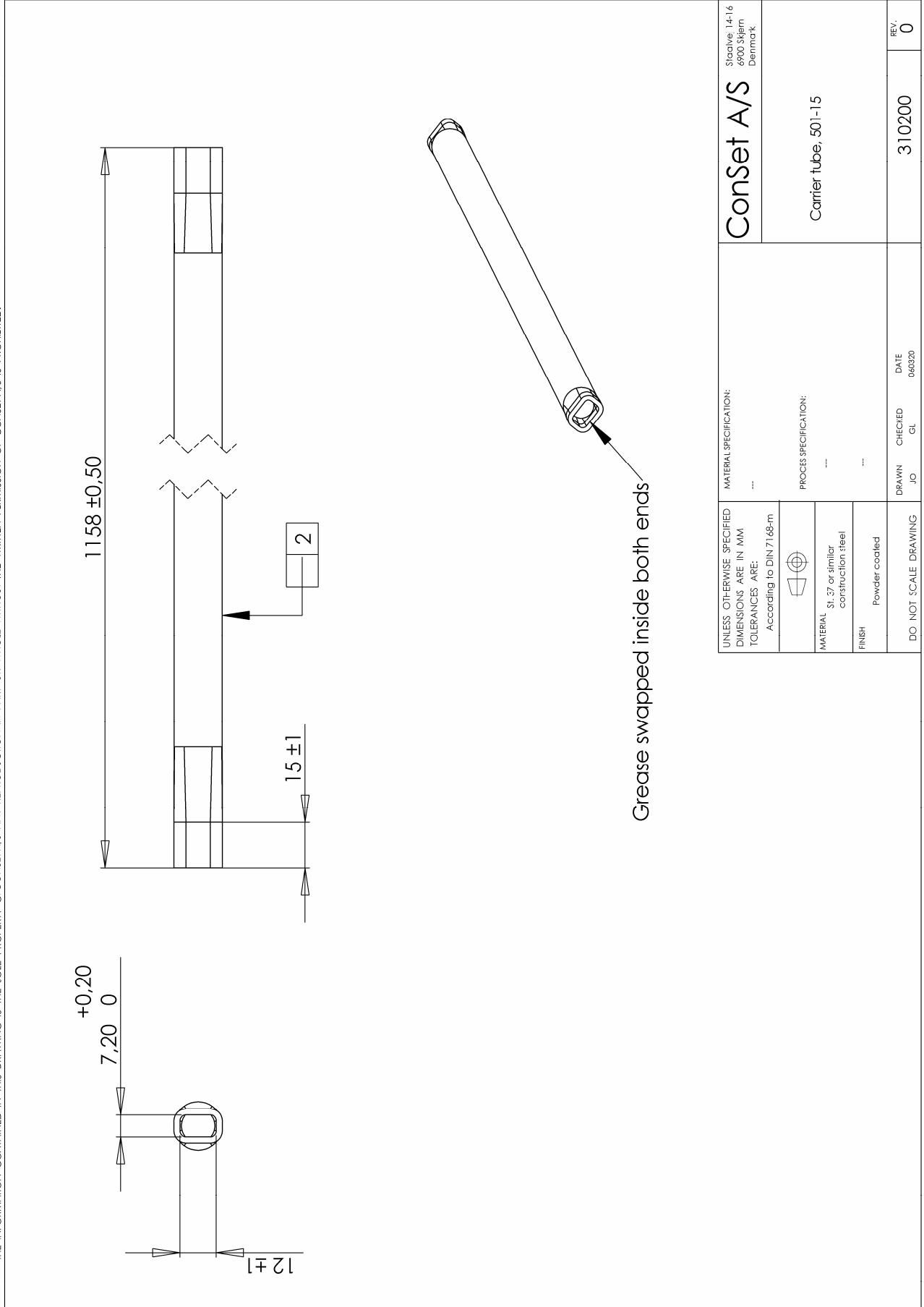

Assembly and use

Along with all products a “Direction for assembly and use” is delivered. In this you will find a detailed description of the way of assembly.

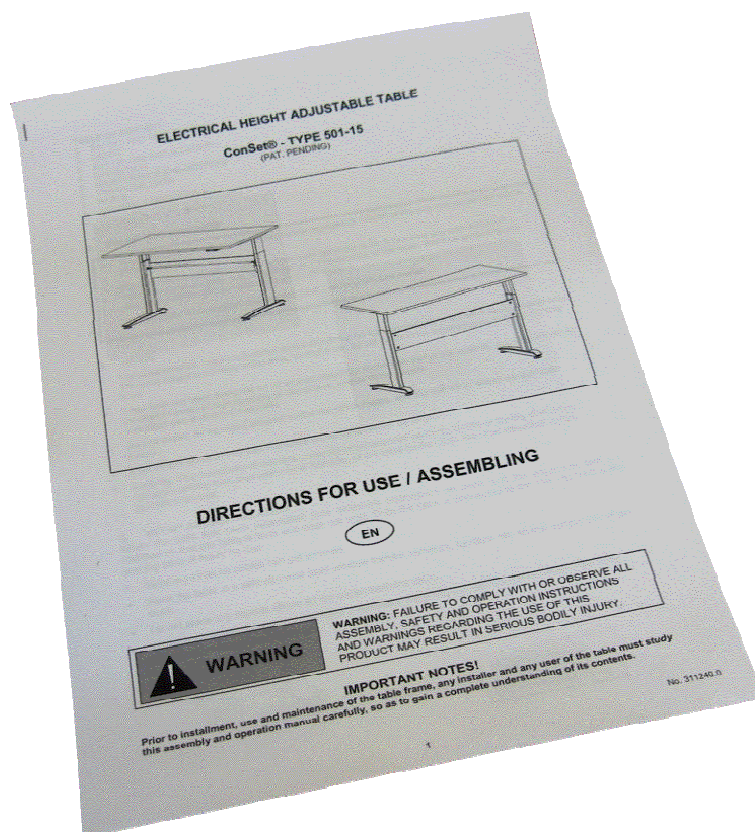

After the frame has been mounted the chosen tabletop is mounted and the operation unit will be possible to fix at the bottom side of the tabletop. This operation unit has two rocker switches.

With rocker switch A and B it is possible to move the tabletop up and down and can be stopped at all levels. For safety reasons it is necessary to push both buttons at the same time for moving the table up and down.

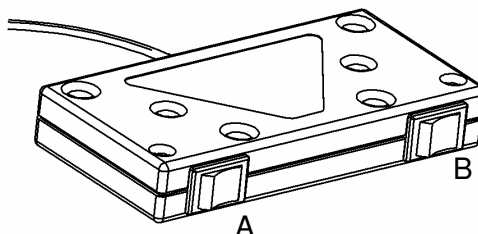

Component specifications

Metal sheet parts:	St 37-2
Gear parts:	St 70-2
Gear motor:	CSE 24V 300047
Power supply:	60 W AC Power Transformer Consumption: 60 Watts; Standby: 0,01 Watts
Plastic components:	PEHD, POM
Surface treatment	Visible metal parts powder coated in black/"alu" colour Non visible metal parts are surface treated (e.g. plated)