

Table of contents

Article numbers	page 3
Packing details	page 4
Bill of material	page 5
Assembly and use	page 6
Dimensions	page 7
Specifications	page 8
Safety & test	page 9

Article numbers

Article number	EAN code
DF019 7SXX1	5 708499 111638
DF019 7SXX1	5 708499 111720

Ordering example

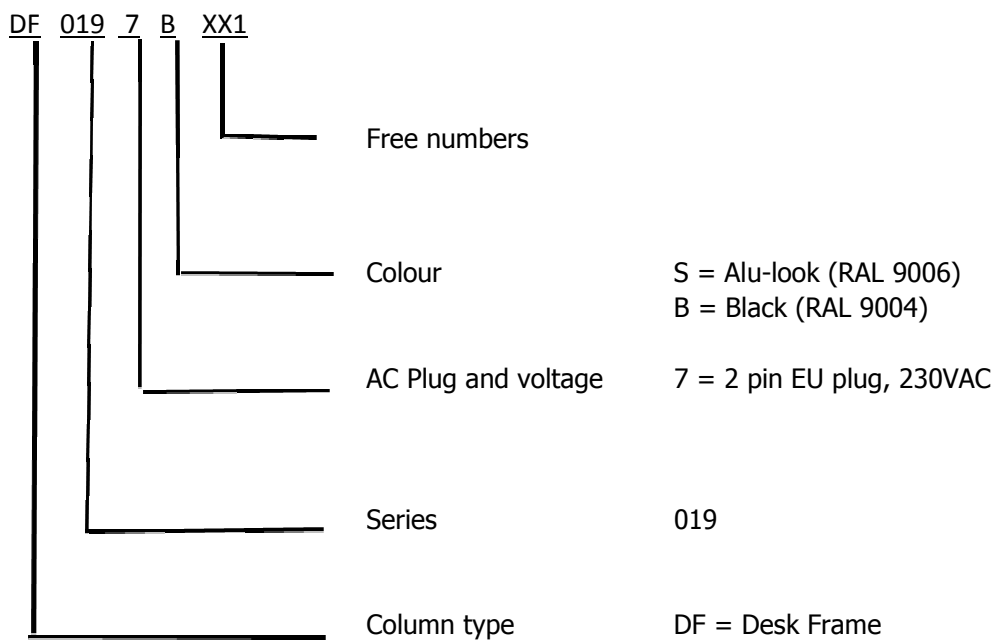

Packing details

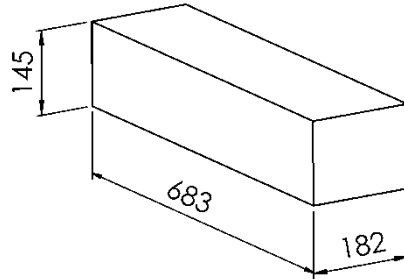

1 pcs.

14 kg

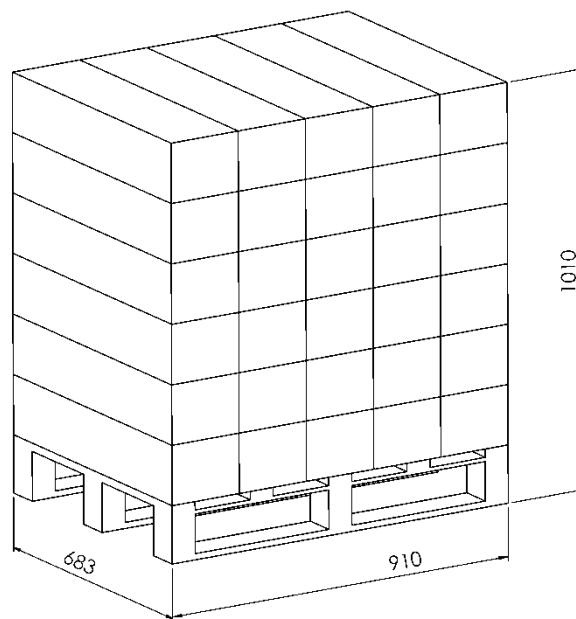

30 pcs.

440 kg

Bill of material

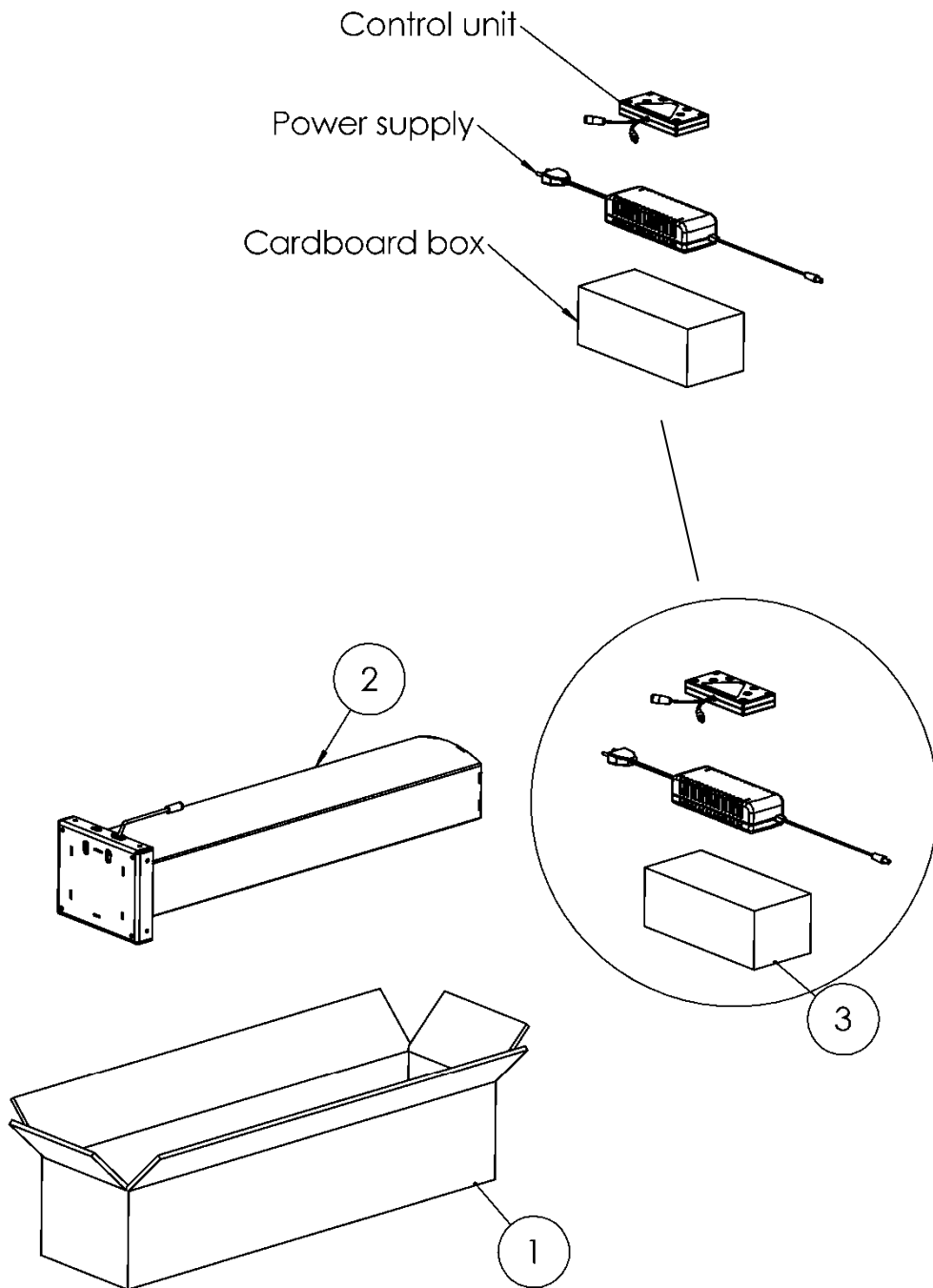

ITEM NO.	QTY.	PART NO.	DESCRIPTION
1	1	312680	Cardboard box
2	1	107900	Lifting column
3	1	108660	Power Box A

Assembly and use

After installation of the column, the electrical components can be connected. All wires have DC jacks and since using different types (size- male/female) only the correct connection will be possible to make.

Along with all products a "Direction for assembly and use" is delivered where all needed information's about the assembly will be accessible.

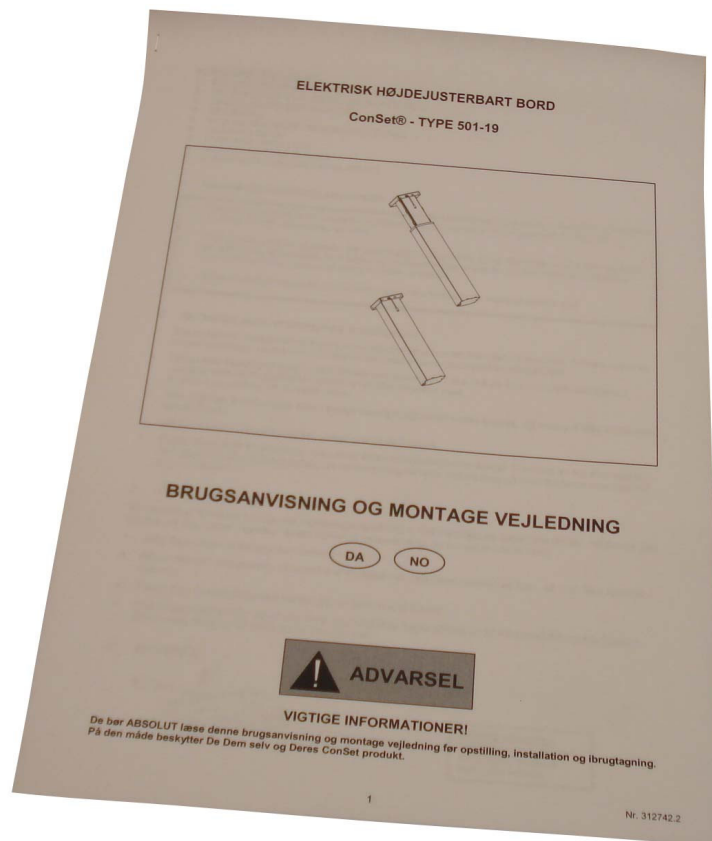

This operation unit has two rocker switches.

With rocker switch A and B it is possible to move the tabletop up and down and can be stopped at all levels. For safety reasons it is necessary to push both buttons at the same time for moving the table up and down.

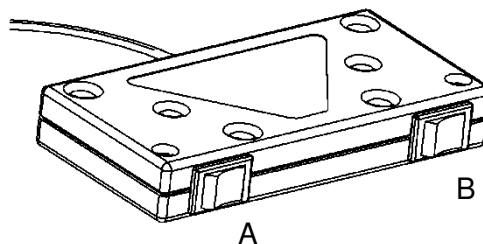

Dimensions

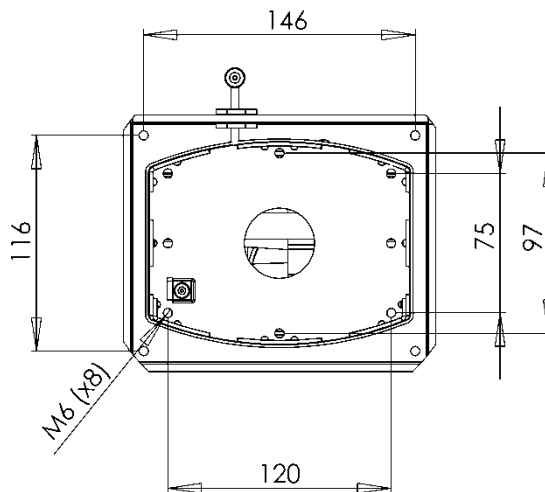
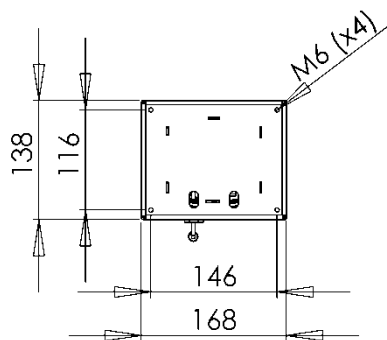
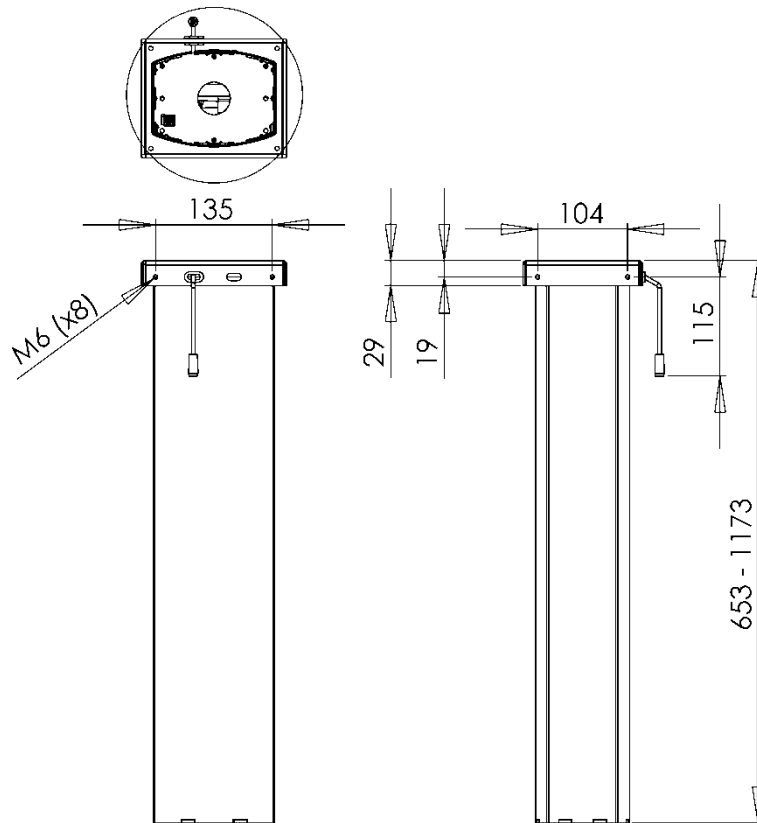

Specifications

Column

Height, frame only	63 – 120 cm
Lifting capacity, frame	150 kilos
Speed	28 mm/sec

Components

Metal sheet parts:	St 37-2
Gear parts:	St 70-2
Gear motor:	Bosch no. 0 390 257 685
Power supply:	120 W AC Power Transformer Consumption: 120 Watts; Standby: 0,01 Watts
Plastic components:	PEHD, PA6
Surface treatment	Visible metal parts powder coated in "alu" colour (RAL9006) or black colour (RAL 9004) Non visible metal parts are surface treated (e.g. zinc plated)

Safety & Test

DECLARATION OF CONFORMITY

We hereby declare, under our sole responsibility that the following products:

- ConSet sit and stand tables product type 501-19

which are covered by this statement, are in conformity with the following standards and other normative documents::

- Counsel Directive 98/37/EF
- Counsel Directive 89/336/EØF with later changes
- Counsel Directive 73/23/EØF with later changes

With reference to the Machinery Directive (98/37/EF) please be aware:

- the sit and stand table is considered a machine and
- the sit and stand table may not be used until it has been assembled and installed according to the instructions.